



ANTENNA TUNER

Model AT-120

OPERATING MANUAL



The Model AT-120 is designed to satisfy your antenna-tuning requirements. The AT-120 has been manufactured the quality and performance that makes Kenwood "The Pacesetter in Amateur Radio".

This unit has been carefully engineered and manufactured under rigid quality standards, and should give you satisfactory and dependable operation for many years.

Should any trouble arise with this unit, please contact your dealer, the nearest KENWOOD service facility, or the factory.

AFTER UNPACKING

Shipping Container: Save the boxes and packing in the event your unit needs to be transported for remote operation, maintenance, or service.

The following explicit definitions apply in this manual.

NOTE: If disregarded, inconvenience only. No risk of equipment damage or personal injury.

CAUTION: Equipment damage may occur, but not personal injury.

FEATURES

1. The AT-120 is a high performance HF antenna tuner and is a modification of the popular AT-200 antenna tuner. The AT-120 is small and light, and is suitable not only for operation in your HAM shack but also for mobile of field operation.
2. The AT-120 consists of an antenna coupler, an SWR meter, and an antenna switch.
3. The AT-120 is designed to be used on the Amateur bands between 3.5 MHz and 30 MHz.
4. Antenna MATCHING or THROUGH operation is BAND switch selected.
5. The SWR meter operates in both THROUGH and MATCHING modes.
6. A mounting bracket is included for mobile operation.
7. The panel meter can be illuminated by an external power source.
8. The antenna matching circuit is effective in reducing TVI since it acts as a band-pass filter.

CONTENTS

AT-120 Specifications	3
Section 1. Preparation for Use	4
Section 2. Controls and their functions	5
Section 3. Operation	6
Section 4. Circuit Description	9
Section 5. Additional Information	10
Schemaict Diagram	11

AT-120 SPECIFICATIONS

1. Antenna Coupler

Frequency range: 5 amateur bands from 3.5 to 29.7 MHz
Input impedance: 50 Ω
Output impedance: 20 to 300 Ω , unbalanced,
Through power: 150 W max. (3.5 MHz band, 120 W)
Insertion loss: Less than 0.5 dB at optimum match.

2. SWR Meter

Frequency range: 3.5 to 29.7 MHz
Max. power: 150 W
Measurable range: 1.0:1 to 10:1
Min. power required: 2 W

3. General

INPUT Connector: UHF type (50 Ω)
ANT Connector: UHF type (50 Ω)
GND: Wing nut and STUD.
Dimensions: 152(6 1/8) x 60(2 3/8)H
x 159(6 1/4)D mm.(inch)
Weight: 1.6 kg (3.5 lbs) approx.

SECTION 1. PREPARATION FOR USE

Accessories:

Carefully unpack your AT-120 Antenna Tuner and verify the following accessories are included.

- Operating manual 1 copy
- Mounting bracket 1 piece
- Mounting hardware
 - Screw, 4 mm diameter 4 pieces
 - Flat washer, 4 mm diameter . . . 4 pieces
 - Lock washer, 4 mm diameter . . . 4 pieces
 - Nut, 4 mm diameter 4 pieces
 - Wing Bolt, 4 mm diameter 4 pieces
 - Polyethylene washer 4 pieces
- 2P power plug 1 piece
- Ground lug 1 piece

Interconnection Cable

To connect your AT-120 with the TS-120S(V), or other transceiver, an interconnection cable is required.

Refer to Figure 1 for details.

Meter illumination power (Figure 2)

Power for the meter lamp is supplied from an external power source. Use the supplied 2P (PIN) plug for power-supply connection. Observe polarity.

[disregard polarity]

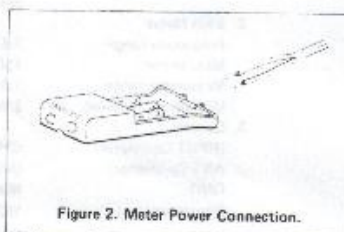
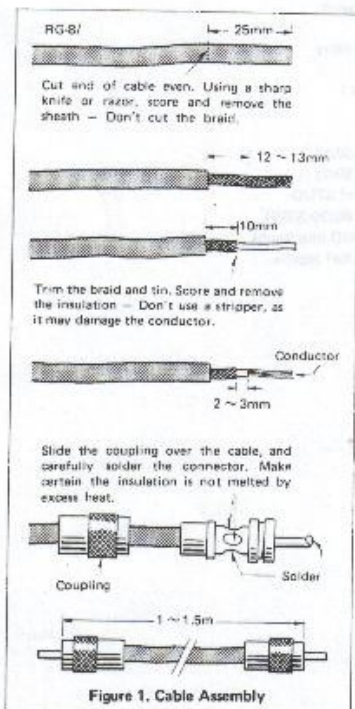

SECTION 2. CONTROLS AND THEIR FUNCTIONS

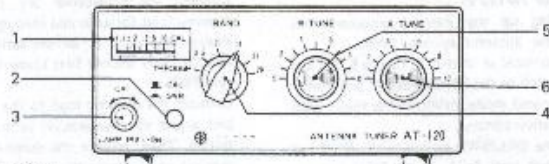

Figure 3. Front view

1. Meter

The meter reads SWR (standing-wave ratio) and is illuminated (external power required).

2. CAL (Calibrate)/SWR Switch

To measure SWR, first set this switch to the CAL (☐) position. Adjust the CAL control until the meter pointer swings to the CAL line on the meter scale.

Then depress the switch to the SWR (■) position, and read the SWR.

3. CAL (Calibrate) Control/Meter Lamp Switch

Before measuring SWR, this control is used to calibrate the meter. Adjust as described above item 2. The meter lamp lights when the control is pulled on.

4. BAND Switch

Set this switch to the band in which you are operating. The BAND switch also has a "THROUGH" position at which the antenna is connected directly to the transceiver. SWR can also be measured at the THROUGH position.

CAUTION: DO NOT operate the band switch while transmitting. Equipment damage **WILL** occur.

5. R TUNE

The R TUNE adjusts the resistive component of antenna impedance.

6. X TUNE (Transmit Tuning) Control

The X TUNE adjusts the reactive component of antenna impedance.

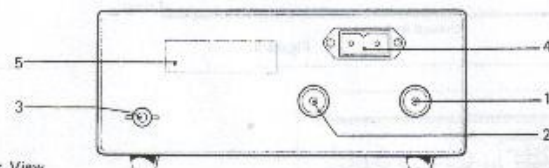

Figure 4. Rear View

1. INPUT Connector

The INPUT UHF connector accepts the HF input signal fed from the antenna connector on the transceiver.

2. ANT Connector

The ANT UHF connector accepts the antenna coaxial cable.

3. GND post

Connect the GND post to the transceiver GND stud. Use as short a cable as possible, using the supplied ground lug.

4. 12 VDC

Accepts 12 VDC for meter illumination. Use the supplied plug.

NOTE: Viewed from the rear, the right terminal is **POSITIVE**.

5. Serial No. Plate

This plate is stamped with the Serial Number of your unit.

SECTION 3. OPERATION

Measuring antenna system SWR

(i) Using an all solid-state transceiver (such as a TS-120S or TS-120 V)

Before setting up the antenna coupler, first determine the antenna system SWR.

- a. Set the controls as shown in Figure 5. Set the BAND switch to the "THROUGH" position.
- b. In the transmit mode, calibrate the meter with the calibration control.
- c. Depress the CAL/SWR switch to the SWR (■) position and read SWR. If the SWR is lower than 1.5:1 the antenna system impedance is sufficiently matched for practical use. If above 1.5:1, tune the system.

NOTE: In the event of too high an SWR (over 10:1), check the antenna system for breaks or a short circuit.

(ii) Using a tube power amplifier transceiver (such as a TS-820)

Connect the transceiver (or transmitter) and dummy load (or antenna) through the AT-120 as shown in Figure 7. Before setting the antenna coupler, you should first know the antenna system SWR.

Connect the dummy load to the ANT connector and adjust the (transceiver or transmitter) final tuning. Then, replace the dummy load with the antenna and measure the antenna-system SWR.

NOTE: During antenna measurements, your transceiver may be operating under heavy loading conditions.

Your signal may also interfere with other stations. Complete measurements as quickly as possible.

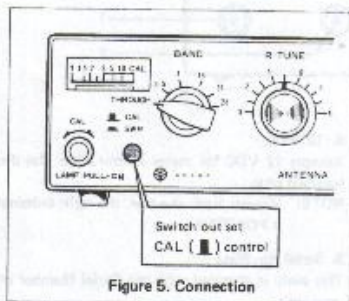
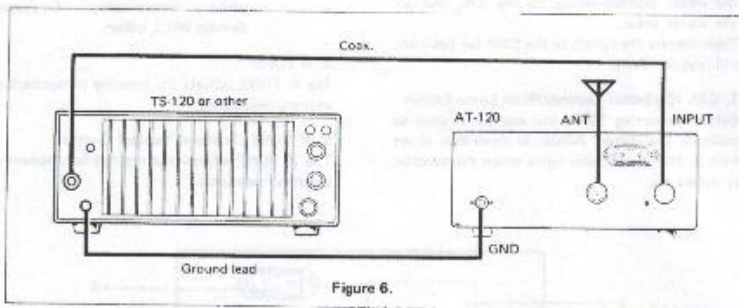

Adjusting the Antenna Coupler

The antenna coupler is used to match a transmitter to an antenna system when its SWR is too high (i.e., greater than 1.5:1 SWR).

- Place the BAND switch to the same band, setting as your transceiver (as shown in Figure 8).
- Set the CAL/SWR switch to the CAL (I) position.
- Transmit and adjust the CAL control so the meter indicates CAL.
- Place the CAL/SWR switch in the SWR (II) position.
- Now you will measure the reflected power. Adjust the R TUNE and X TUNE controls alternately for a good minimum meter indication. Reflected power will be close to zero as a good match is achieved.

Table 1 shows control positions for coupler adjustment.

Table 1.

BAND (MHz)	R TUNE	X TUNE
3.5	4.0	5.0
7	4.9	4.8
14	7.0	7.8
21	8.1	8.1
28	8.2	8.1

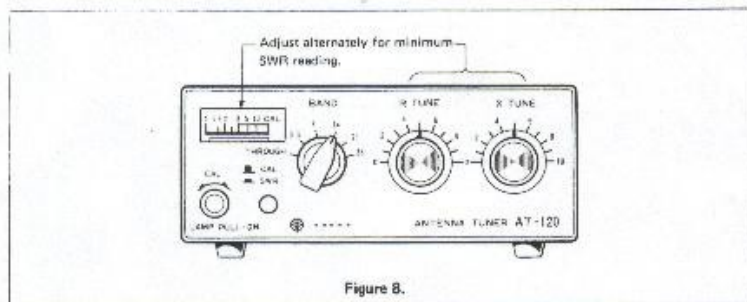
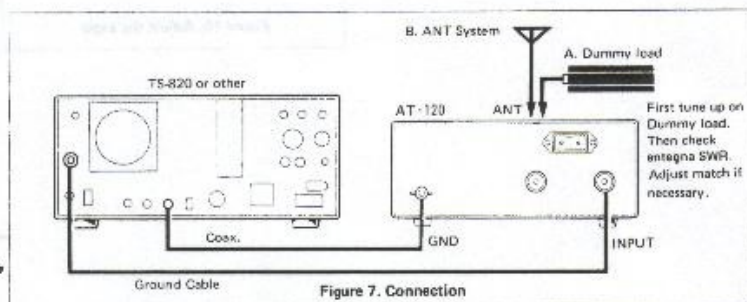

AT-120 Mobile Installation (Figure 9, 10)

Securely install the Mobile Mount using four lock washers, four flat washers, and four screws and nuts. Install the AT-120 in the Mobile Mount by four wing bolts and polyethylene washers. Adjust the tilt before tightening the bolts.

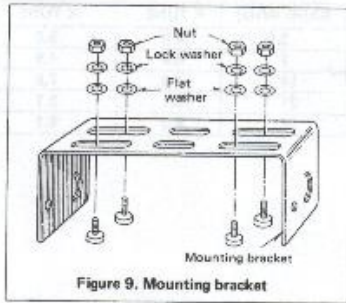

Figure 9. Mounting bracket

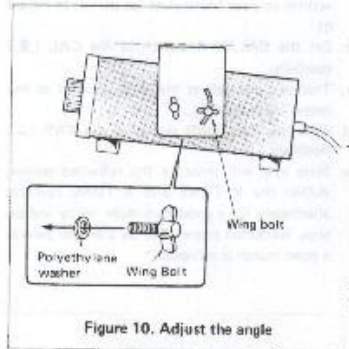

Figure 10. Adjust the angle

SECTION 4. CIRCUIT DESCRIPTION

Figure 11 shows a block diagram of the AT-120.

Directional Coupler

The directional coupler samples forward and reflected power from the transceiver to the load.

Meter Circuit

The forward and reflected power sampled by the directional coupler is used for SWR measurement. Forward power is calibrated with the CAL control so reflected power is read as SWR.

Band Selector Switch

This selects the band to which the matching circuit is tuned. In the "THROUGH" position, the antenna is connected directly to the transceiver, by passing the coupler, while still allowing SWR measurement.

Antenna Coupler

The universal matching circuit is capable of matching 20 to 300 Ω loads to the 50 Ω input impedance.

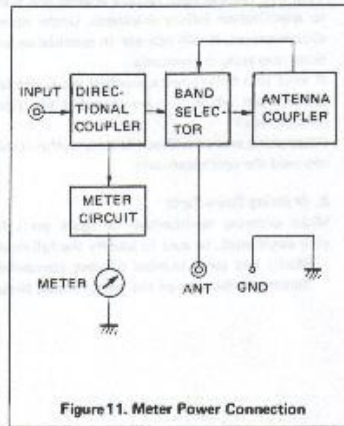

Figure 11. Meter Power Connection

SECTION 5. ADDITIONAL INFORMATION

1. General Information

Your AT-120 has been factory aligned and tested to specification before shipment. Under normal circumstances, it will operate in accordance with these operating instructions.

If your unit fails to work, contact the authorized dealer from which you purchased it for quick, reliable repair.

Attempting service without factory authorization can void the unit's warranty.

2. Ordering Spare Parts

When ordering replacement or spare parts for your equipment, be sure to specify the following:

Model and serial number of your transceiver,
Schematic number of the part. Printed circuit

board number on which the part is located, Part number and name, if known, and Quantity desired.

3. Service

Should it ever become necessary to return the equipment for repair, pack in its original box and packing, and include a full, detailed description of the problems involved. Also include your telephone number.

You need not return accessory items unless they are directly related to the service problem.

NOTE: When claiming warranty service, please include a photocopy of the bill of sale or other proof of purchase showing the date of sale.

SCHEMATIC DIAGRAM

The circuit elements may be changed without notice owing to technical innovation.

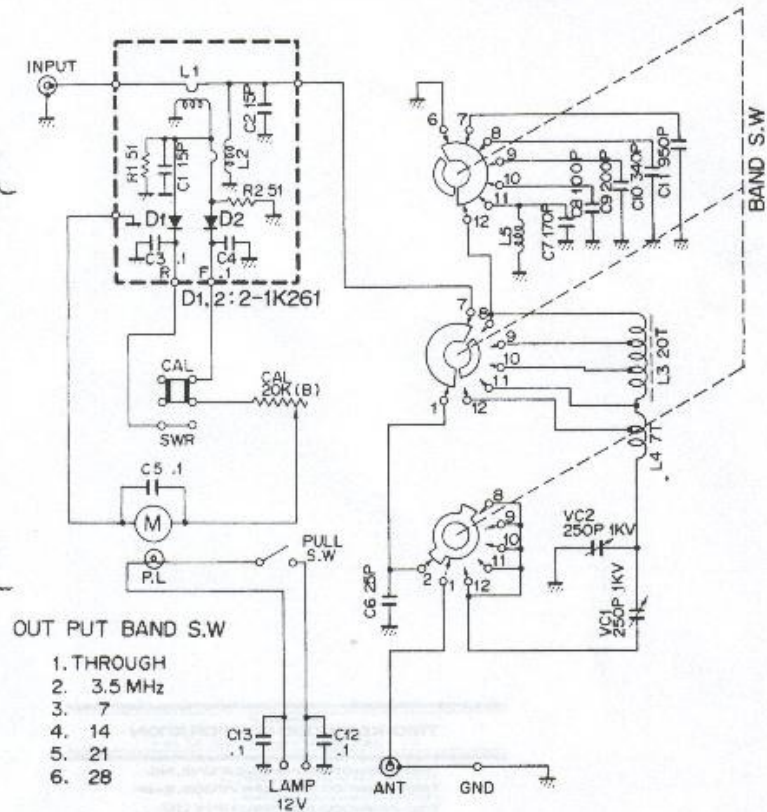

AT-120

SCHEMATIC DIAGRAM

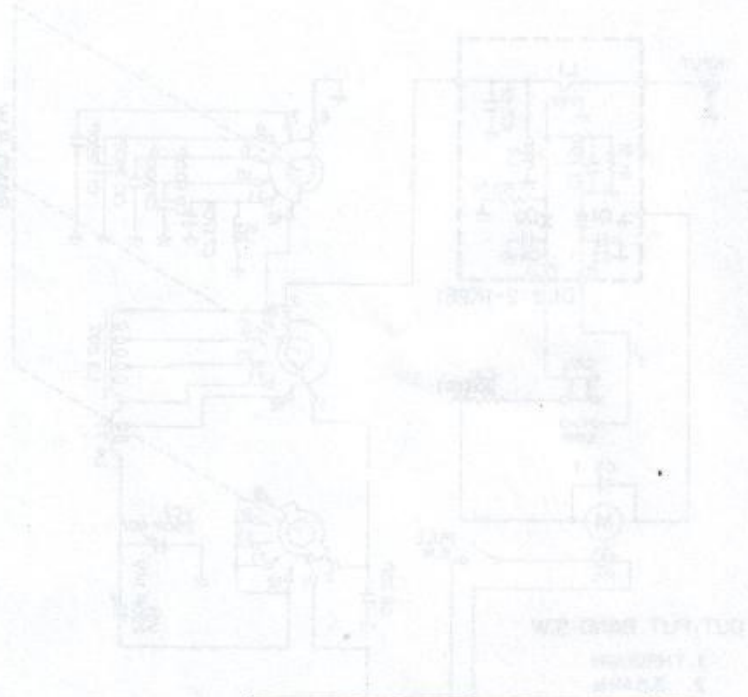

A product of
TRIO-KENWOOD CORPORATION
5-1-3 Chome, Aoyama, Minato-ku, Tokyo, J.S. Japan

TRIO-KENWOOD COMMUNICATIONS, INC.
111 West 42nd Street, New York, N.Y. 10018, U.S.A.
TRIO-KENWOOD COMMUNICATIONS, GmbH
Postfach 10, 4000 Düsseldorf 1, Germany
TRIO-KENWOOD AUSTRALIA PTY. LTD.
30 Warring Street, North Sydney, N.S.W. 1585, Australia

OSI-TA

© 9482 PRINTED IN JAPAN B50-2666-08(K.O)